

## Controlled Switching Technology

SC-A3

PS3 - Q14

*“Control switching technology, known for about 30 years, seems to experience a renewed interest and applied more and more frequently. What is reason for that? Higher reliability, more trust in this technology, possibility to be integrated in IEC 61850 digital substations?”*

Dzevad Pita (AUS)



# Controlled Switching Technology – Australia / NZ Experience

AUS/NZ experience with Control Switching is around 25 years

## Main reason is to reduce/eliminate stress on:

- Circuit breakers
- System insulation
- Power transformers
- Capacitor banks
- Reactor banks
- Network voltage fluctuation/deepness (in a week part of network)



## Applications/Issues:

### ○ Capacitor Bank or Filter Bank

- Main issue: Inrush current during the energisation.
- Grounding arrangement important for control switching
- Controlled **closing** strategy is to close at voltage zero across the CBs contacts.
- Controlled **opening** strategy is to avoid short arcing time resulting in reignitions or restrikes.

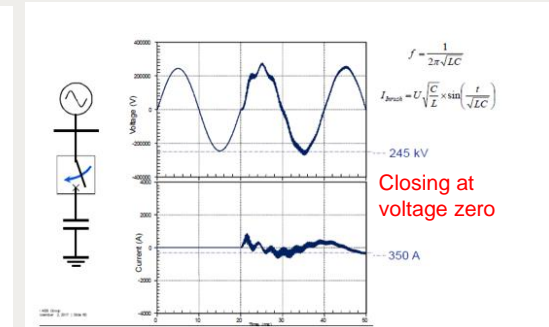
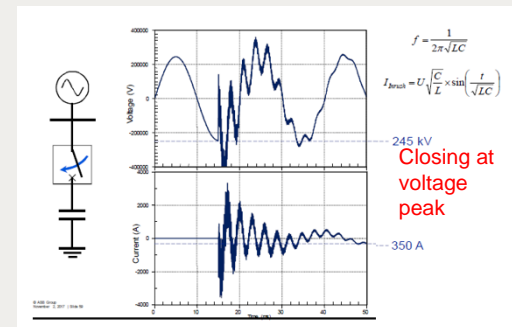

Group Discussion Meeting

# Controlled Switching Technology – Australia / NZ Experience

AUS/NZ experience with Control Switching is around 25 years

## ○ Shunt Reactors

- Main issue: Reignitions as result of de-energisation
- Reactor core and winding arrangement important for POW
- Controlled **opening** strategy is to select arcing time long to avoid re-ignition.
- Controlled **closing** strategy is to energise at instant resulting in flux symmetry.

## ○ Power transformers

- Main issue: Inrush current during the energisation
- Transf. core and winding arrangement important for POW
- Controlled **closing** strategy is to energise no-load transformer at instant resulting in flux symmetry by taking residual flux into account.
- Controlled **opening** strategy is important as it serves as support for the consecutive controlled closing.

- **Overhead Lines** - Main Issue : switching overvoltages during the energisation

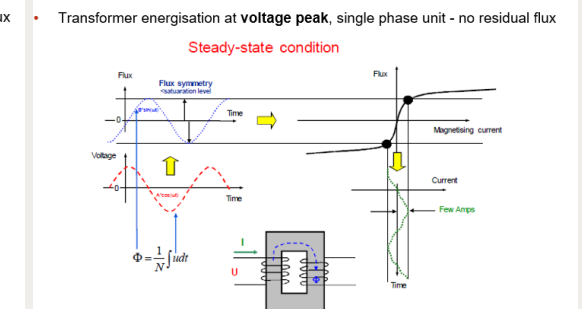
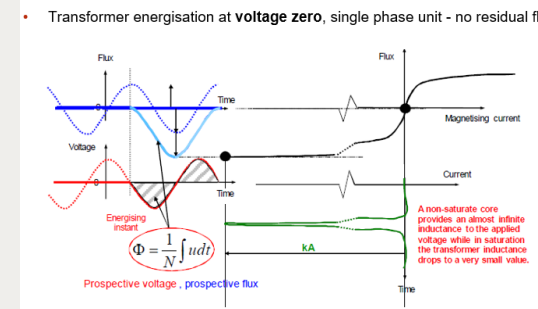
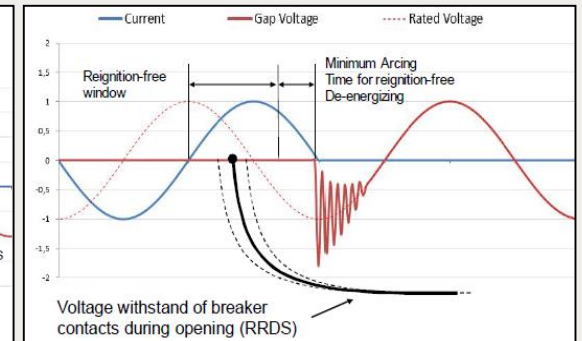
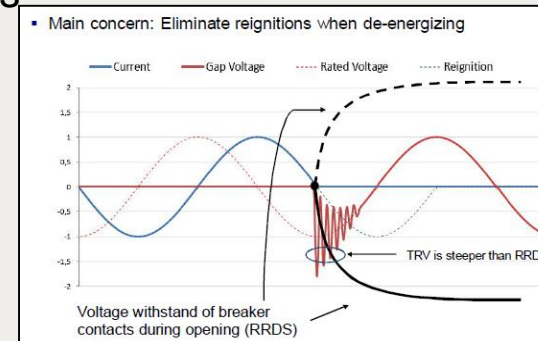

# Controlled Switching Technology – Australia / New Zealand Experience

## Relay Types (Current):

- CSD 100 (RPH4) – GE
- PWC600 - ABB/Hitachi
- SSC-SP1 – Mitsubishi
- PSD02 – Siemens

## Circuit Breakers:

- Single Pole operated – preferred
- Three pole staggered (grounded or U/G capacitor banks/filter banks) – poles mechanically dependant, harder for adaptive control

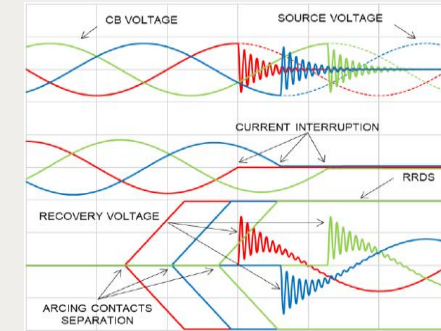
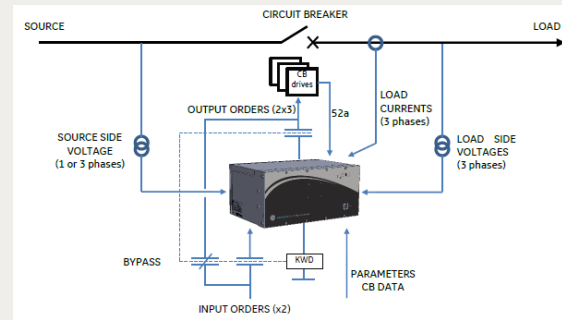

## POW Integration Through IEC 61850:

- Implemented on 300kV Reactors at Braemar S/S on PASS M1 Units. Unfortunately both units have catastrophically failed due to multiple reignition. This was due to the initial settings given by the manufacturer did not achieve the minimum arcing time required for its application which makes the CS to give the opposite result.
- POW implemented through PWC 600

## Challenges:

- Use of one type POW relay for various CB brands?
- How to accurately perform control switching for Transformers if CB is located 2-3 kms away?

Group Discussion Meeting