

Questions 1.04: Are there any key considerations for securing the ROCOF protection against maloperation?

- The South African Grid Code requires that ROCOF is applied at the POC by the inverter-based operator according to the following requirements.
 - The generator facility shall be equipped with effective detection of islanded operation in all system configurations and capability to disconnect all co-generating units from the TS or DS or shut down generation of power in such conditions within 2 seconds. Islanded operation with part of the TS or DS is not permitted unless specifically agreed with the System Operator (SO) or local distributor. Internal islanding on local load for embedded co-generating units is allowed and will be under the full control of the co-generator and the host industrial plant.
 - The generator shall remain connected to the IPS during rate of change of frequency values up to and including 1.5Hz per second provided the frequency remains within the frequency operating range specified below:

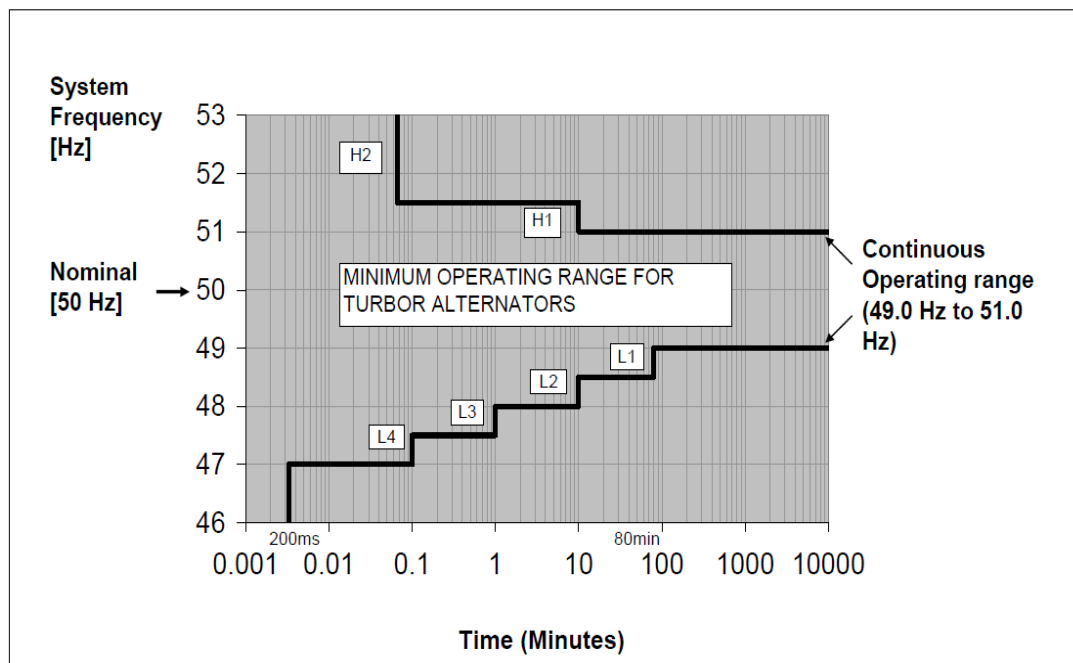

- The generator shall make provision to receive an external dual bit inadvertent island status signal from the SO or local distributor which will cause all co-generating units within its facility to disconnect from the TS or DS within 2 seconds.
- The generator shall be responsible for all automatic synchronizing facilities to enable reconnection to the TS or DS following internal islanding conditions. In addition, synch-check facilities shall be provided at the POC to prevent out-of-sync reconnection in all conditions.
- The generator shall ensure that its facility is dimensioned and equipped with the necessary protection functions so that it is protected against damage due to faults and incidents in the TS and DS.

- In addition, the network service provider also provides additional security by ensuring that remotely detected potential islanding conditions are prevented through inter-tripping schemes. Such applications are targeted at ensuring that the generator is able to disconnect without sustaining connected load due to lack of visibility of network faults upstream from the POC.

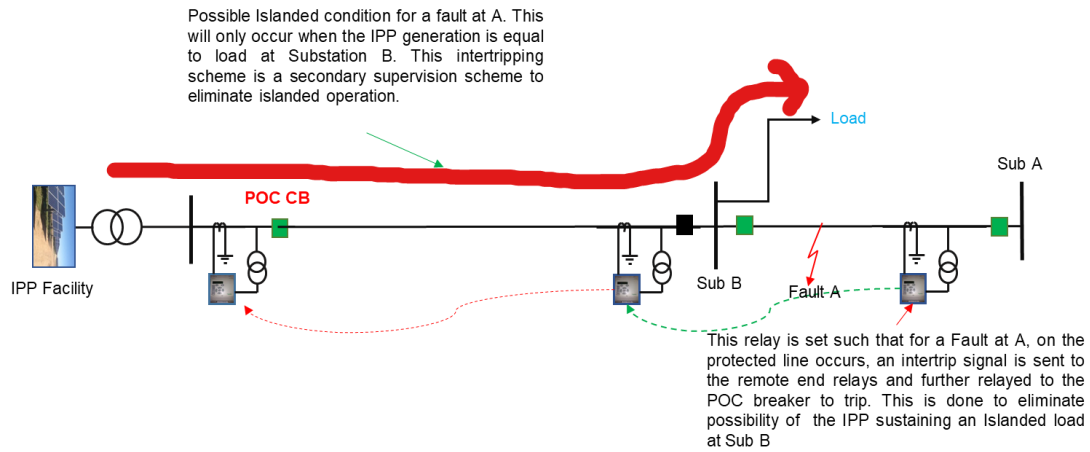

- During commissioning, the inter-tripping scheme is tested by verifying that the signal to disconnect is being received at the relevant point within the network.
- When ROCOF is applied locally, a physical test is conducted where a small load is connected to the plant and rejected to test the effectiveness and security of the function.
 - This physical testing is only done for small synchronous machines (hydro generators). For inverter-based generators, normal relay injections are deemed sufficient for testing the function.