

## Study Committee B5

Protection and Automation

Paper 10804\_2022

### Novel Approach to Implementation of Fully Digital Substation Expectations on Pilot Project Sigtuna 130/20 kV Substation

Anders JOHNSON

Florin STELEA

Yiming WU

David EROL

Vattenfall Eldistribution AB

DNV Sweden AB

Vattenfall AB

Vattenfall AB

#### Introduction with background

The IEC 61850 standard station bus is well established as solution for digital Protection, Automation and Control Systems (PACS). Swedish DSO Vattenfall Eldistribution has accordingly established technical requirements and software tool based work processes for specification and implementation of IEC 61850 bus-based substations that covers the bay level application of PACS. An expansion towards the process bus is the natural next step.

#### Drivers for digital substations

Less life cycle cost comparing to just station bus solution

- 6-12% less CAPEX for brownfield installations
- 13-19% less CAPEX for greenfield installations

Savings are generated by:

- less area for control room buildings, use of cable PVC conduits instead of cement cable trenches, reduced number of control room cabinets, local HMI etc

#### Goals of pilot project

- Validate and verify the expected benefits
- All parts of the installation fully commissioned and operational without piggy-back solutions
- Support the development of a complete concept for future digital substations, in line with asset management strategies
- Prepare for future use of new technologies (i.e. LPIT, additional information for use by enterprise applications)
- Contribute towards data-driven DSO (company goal)

#### Novel approaches to implementation

The innovative parts focus on a conceptual solution for the 130 kV side. The basic principles include a novel separation/allocation of functions on process, bay and station level in a mixed environment of redundant networks.

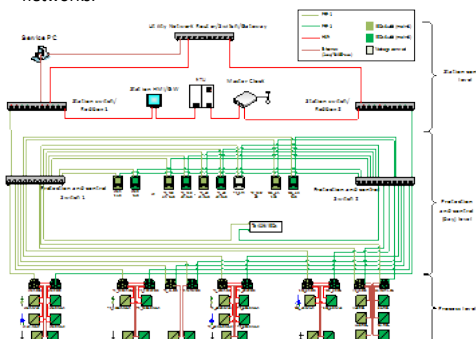

The complete PACS is divided in two parallel main-systems where distributed marshalling kiosks are accommodating parallel merging units with process bus.

- Modularized HW/SW
- Local control only at the HMI on the PACS terminals
- Microsecond accuracy for time synchronization
- Station data gateway for non-time critical data delivery for multi-purpose enterprise services
- System management and monitoring on all levels
- Digital tool based test systems

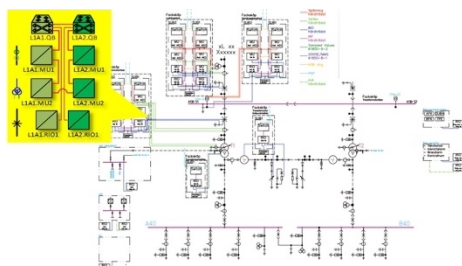

Conceptual solution of PACS

#### Pilot and demo station Sigtuna

The 130 kV part would be equipped with a fully digital PACS with IEC 61850 process bus. The 10 kV and 20 kV parts would be built solely with IEC 61850 station bus

#### Project execution model and development phase

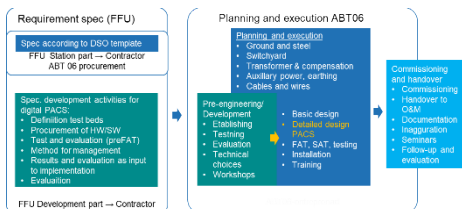

1. Functional performance for protection function
2. Communication traffic behavior
3. Expenditure (cost) analysis
4. Time synchronization accomplishment
5. Information observability
6. Supervision and Functional testing system feasibility
7. IT-security compliance

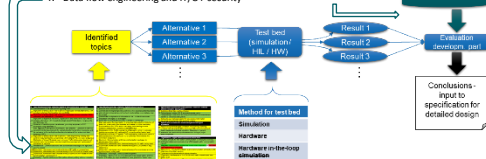

#### Success criteria

- Criteria for the project to be considered a success:
- Established descriptions of engineering work process to build digital substations that covers all levels, and test and monitoring method and supporting tool set
  - Verified reduced CAPEX part of lifecycle-costs
  - Verified technical solution

#### Status, results and conclusions

- Several offers on digital substation were received.
- Termination of the procurement due to high cost.
- Development part drives large budget (contractor).
- Expected benefits remains.
- Increased supplier experience on digital PACS.
- DSO plan to establish test facility with partner.