

## Study Committee B5

Protection and Automation

Paper 10153\_2022

### ITAIPU AND ANDE PREPARATION FOR THE PARAGUAYAN- ARGENTINEAN INTERCONNECTION

Jonas Roberto PESENTE, Robson Almir de OLIVEIRA, André Pagani TOCHETTO, Alfredo Mezger SZOSTAK, Jhonatan Andrade dos SANTOS, Manuel Leonardo SOSA-RIOS, Paulo Henrique GALASSI, Itaipu Binacional, Brazil  
Jose Maria Barua GODOY (in memoriam), Elizandro RODRIGUEZ, Gustavo AGUAYO, ANDE, Paraguay

## Motivation

- Major interconnection between Paraguayan and Argentinean Power Systems
- Development of solutions to enable safe operation of both systems

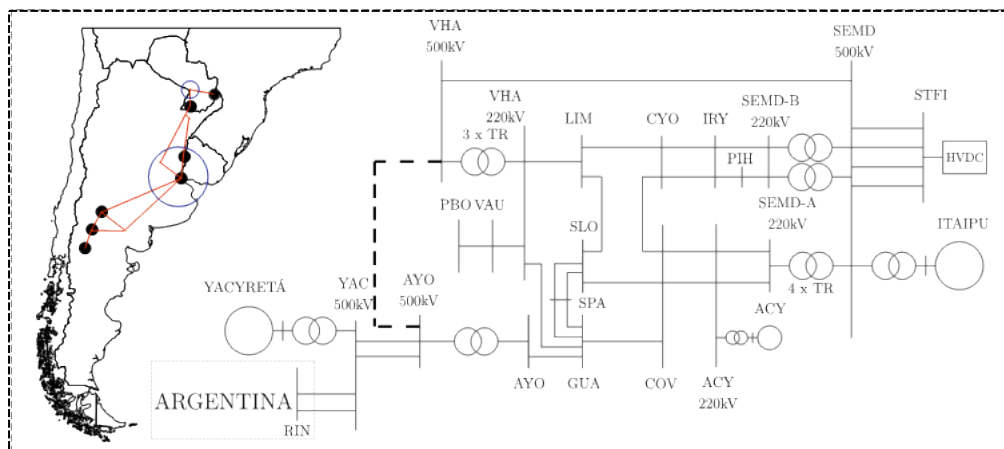

## Requirements identified:

- Design of a Special Protection Schemes with islanding control actions
- Design of backup logic functions for SPS
- Tuning of:
  - Itaipu 50Hz PSS
  - Primary and secondary loops of load-frequency control
  - Primary and secondary loops of voltage control
- Modification of existing SPS in Itaipu



## Study Committee B5

Protection and Automation

Paper 10153\_2022

### ITAIPU AND ANDE PREPARATION FOR THE PARAGUAYAN-ARGENTINEAN INTERCONNECTION

Jonas Roberto PESENTE, Robson Almir de OLIVEIRA, André Pagani TOCHETTO, Alfredo Mezger SZOSTAK, Jhonatan Andrade dos SANTOS, Manuel Leonardo SOSA-RIOS, Paulo Henrique GALASSI, Itaipu Binacional, Brazil  
 Jose Maria Barua GODOY (in memoriam), Elizandro RODRIGUEZ, Gustavo AGUAYO, ANDE, Paraguay

## HIL and field testing

- Dynamical power system modeling
- FAT and HIL testing
- Interconnected operation testing

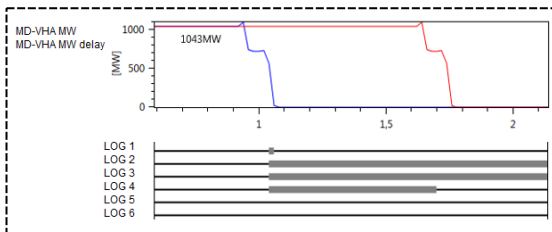
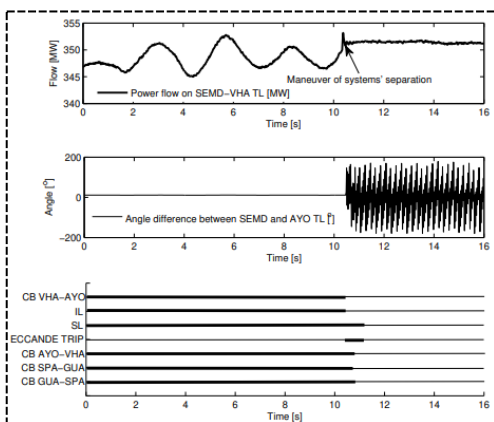
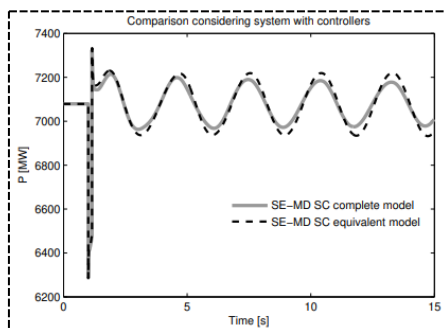

Table II  
 Complete and equivalent models statistics

Number of	Complete	Equivalent
Buses	3849	22
Lines	2682	28
Transformers	2507	8
Generators	292	3
Controllers	307	9
Individual loads	225	0
Shunt bus-connected	124	3
Shunt line-connected	110	0
Static compensator	5	0
Shunt bank	331	3
SPS	24	0
Protection models	118	0
Av. time sim.(50s)	44min52s	1.64s



## Conclusion

- From implementations and field testing, We believe the adequate preparations for interconnected operation were performed to enable a controlled risk future operation