

Study Committee B5 – Protection & Automation

PS3 / INTEGRATION OF INTELLIGENCE ON SUBSTATIONS (JOINT PS WITH B3)

Paper B5-10641

Large scale application of fully Digital Substations at LANDSNET, Iceland

Birkir Heimisson¹, Theodor Jónsson¹, Priyanka Mohapatra², Fred Steinhauser²

1. LANDSNET (Iceland) 2. OMICRON electronics GmbH (Austria)

Introduction

- LANDSNET system operator in Iceland
- Owns and operates 83 substations and 3526 km of transmission lines and cables
- In the process to roll out 20-24 fully Digital Substations [2019-2024]
- All C&P application based in IEC 61850 standard with multi vendor approach
- Transition over to Low Power Instrument Transformers (LPIT)

Digital Substation overview

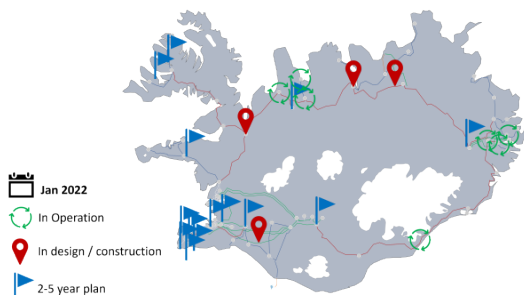

Application Area 1: Technical Requirements & Top-Down Engineering

- Initially lack of clarity and details regarding specifications and requirements
- At first there was only reference to the IEC 61850 standard
- Today LANDSNET has its own specifications and requirements, including details in SCL files and a top-down engineering design process

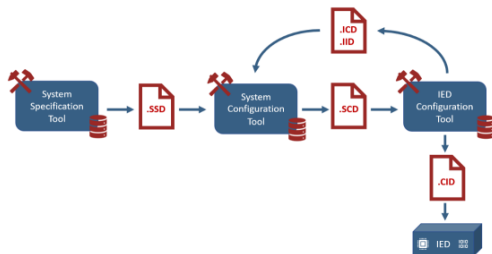

- Detailed requirements to follow the IEC 61850 data model, e.g. minimize the use of GGIO/GAPC
- Allocation of logical nodes (LN) in appropriated devices according to IEC 61850-5 device model

Motivation

- LANDSNET made strategic decision in 2019 that all new and refurbished substation should be fully digital

- Utilizing latest technology
- Personal safety
- Reducing TOTEX investment cost
- Increased flexibility in operation and smart-grid dev.
- Improve sustainability [housing, copper, transport ...]
- Offsite testing, monitoring & maintenance
- More efficient design and commissioning
- LANDSNET own standardisation and requirements

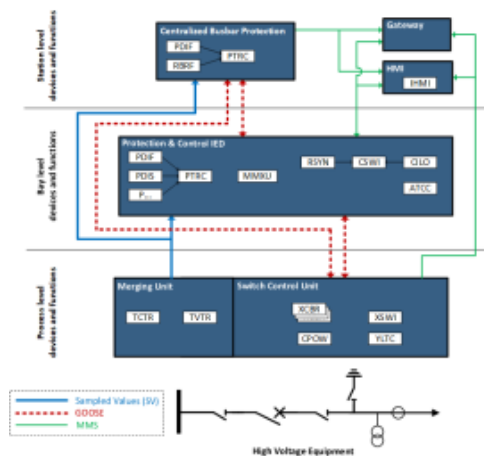

Study Committee B5 – Protection & Automation

PS3 / INTEGRATION OF INTELLIGENCE ON SUBSTATIONS (JOINT PS WITH B3)

Paper B5-10641

Large scale application of fully Digital Substations at LANDSNET, Iceland

Birkir Heimisson¹, Theodor Jónsson¹, Priyanka Mohapatra², Fred Steinhauser²

1. LANDSNET (Iceland) 2. OMICRON electronics GmbH (Austria)

Application Area 1: Continued

- Topics which were revised, standardised and optimized within LANDSNET as part of the digital journey:

Design Memorandum

Tender Specification

.SCL Engineering

System Architecture

P&C Philosophy

Implementation Guide

Testing Philosophy

- C&P applications: Devices vs. Functions
- Redundancy of C&P with Main 1 and Main 2 devices
- LANDSNET reevaluated the protection philosophy
- Some application still lacking digital maturity [metering, PQ, traveling wave ...]

Application Area 2: Network Architecture and Time-synchronisation

- At onset the communication architecture was still under evolution
- LANDSNET has now standardised PRP redundancy
- PTP time-sync is the heartbeat of digital substation, LANDSNET requires redundant grand master clocks
- First architecture with physical segregation between station- and process bus introduces some drawbacks

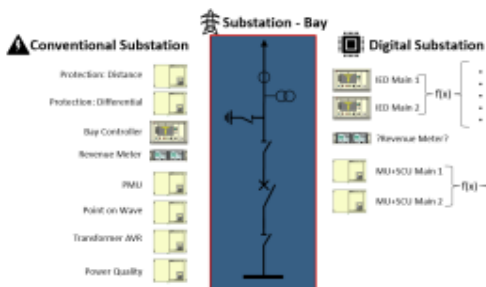
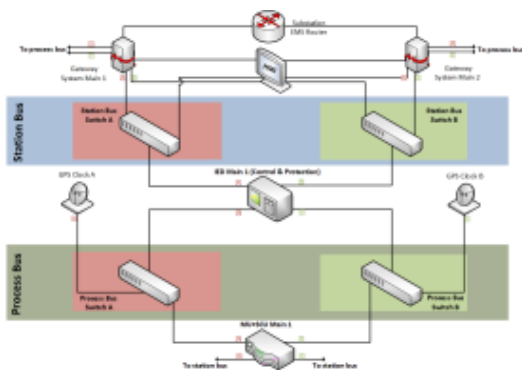

- LANDSNET now emphasis on single subnet architecture [IEC 61850 network]
- Concept of station- and process bus is virtualized with use of Destination MAC-address filtering and/or VLANs.

Key Challenges Identified

Data Models not according to IEC 61850

Software bugs in IED configuration tools (ICT)

Interoperability issues due to different standard interpretation of various vendors

Problems solved with cooperation between different parties

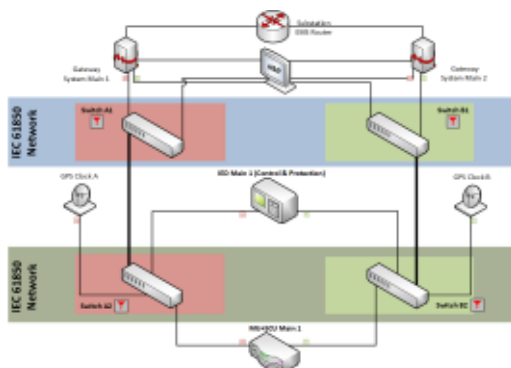

Study Committee B5 – Protection & Automation

PS3 / INTEGRATION OF INTELLIGENCE ON SUBSTATIONS (JOINT PS WITH B3)

Paper B5-10641

Large scale application of fully Digital Substations at LANDSNET, Iceland

Birkir Heimisson¹, Theodor Jónsson¹, Priyanka Mohapatra², Fred Steinhauser²

1. LANDSNET (Iceland) 2. OMICRON electronics GmbH (Austria)

Application Area 3: Testing and Commissioning of Digital Substations

- Completely new approach to testing and commissioning
- FAT has become a lot more comprehensive
- Digital journey has pushed for more automation and optimization in processes and data handling, e.g. signal lists, IED configuration, prot. settings (.XRIO) & test plans
- Focus on full system testing:

- ✓ SCD verification
- ✓ Signal testing, analogous to point2point
- ✓ Network testing
- ✓ Network configuration testing, e.g. filtering
- ✓ Time synchronisation testing
- ✓ Signal test to HMI and SCADA
- ✓ Interlock testing
- ✓ All C&P functions testing

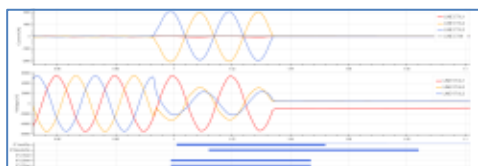
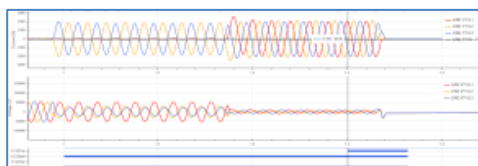

- Since the commissioning of the first digital substations in 2021, few disturbances have been experienced by the new digital protections.

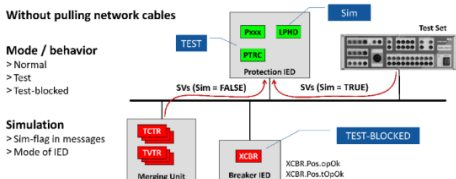

- LANDSNET emphasis on using and requiring IEC 61850 Ed2.0 testing features with the use of Mode/behaviour and the Simulation-Flag
- Outageless maintenance and testing has been achieved in live system at LANDSNET

On the Horizon

- Fully redundant control strategies with gateway processing single source of signal towards the SCADA
- Inter-substation communication with IEC 61850 data
- Operating single ended differential protection using SV instead of IEEE C37.94

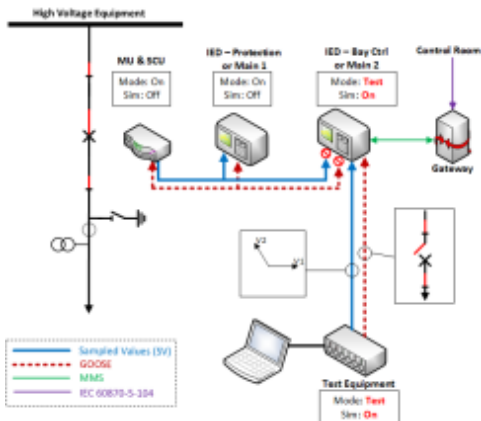
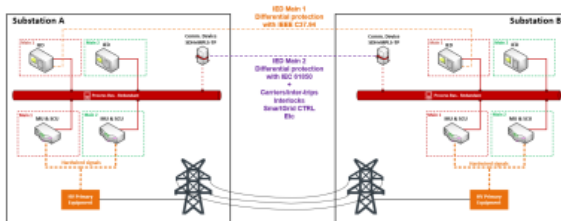

Conclusion

- Digital Substations are a feasible option, and the operational experience so far is good and without any major issues
- Key lesson learned is to define utility own specifications and requirements
- Not necessary to be perfect at first. Simply consider key outcomes from experience around the world.
- Establish good collaboration with all parties to ensure seamless delivery of digital substations
- LANDSNET is optimistic for the operation of these flexible digital assets for the future to come